

HE2 Knife Sharpening System

The HE2 Knife Sharpening System combines blade thinning and honing/edging operations into a single, compact machine

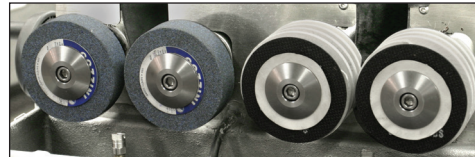

Shown with optional cart



Grinding
Stones

Honing
Stones

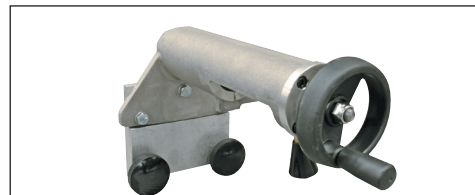

Dresser assembly

PRIMEEdge®
COZZINI CUTTING EDGES
AND SHARPENING SOLUTIONS

HE2 Knife Sharpening System

- All-in-one unit with grinding and honing stones.
- Unique spiral-shaped honing/edging stones design ensures consistent, smooth, sharp edges.
- Sharpens blades up to 10" (254 mm) long.
- Recirculating liquid coolant system provides burn-free and dust-free operation.
- Integrated stone dressing system maintains roundness of the stones for perfect, consistent, sharp edges.
- Optional cart available.
- CE approved.

REV 06/14/2018

PRIMEEdge®
COZZINI CUTTING EDGES
AND SHARPENING SOLUTIONS

877-322-EDGE(3343) • primedge.com • sales@primedge.com • Fax:224-265-6638

HE2 Knife Sharpening System

Ideal for smaller meat processors, supermarkets, hardware stores and sharpening services, the compact **PRIME**edge HE2 Knife Sharpening System provides the same benefits as the larger capacity **PRIME**edge sharpening systems utilizing separate hollow grinding and honing/edging units.

The Ø4" (102 mm) grinding stones of the unit thin both sides of the blade simultaneously. The operator checks the blade thickness with a built-in gauge to determine if it has been sufficiently thinned. After thinning, the honing/edging stones apply a beveled edge on both sides of the blade simultaneously. The blade bevel angle can be adjusted as needed.

The HE2's cast aluminum body is housed under a durable, easy-to-clean, stainless steel cover. Though the HE2 can be used as a tabletop grinder, an optional cart with casters allows for easy portability.

For a precise cutting edge every time, trust the proven HE2 Knife Sharpening System from **PRIME**edge.

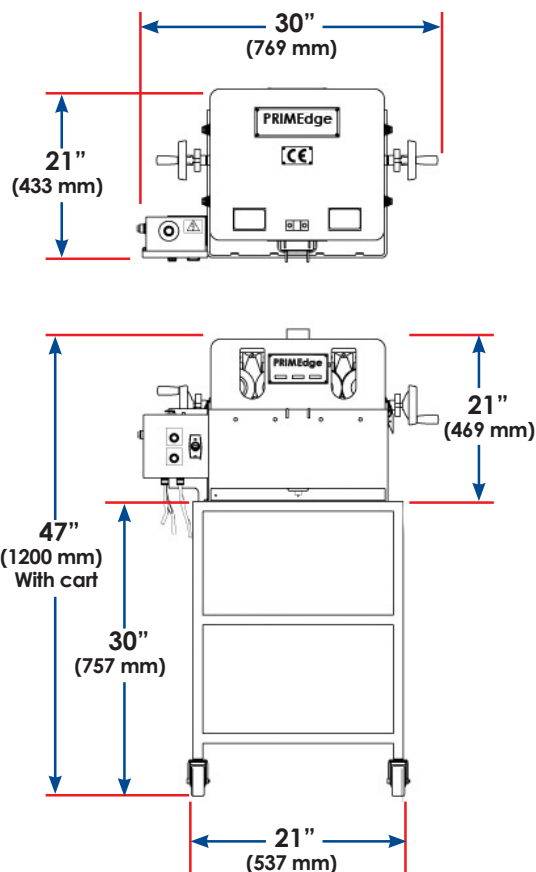

HE2 Knife Sharpening System			
Voltage	Frequency	HP	kW
115V	50 or 60 Hz	1	.75
220V		3/4	.56

PRIMEedge[®]
COZZINI CUTTING EDGES
AND SHARPENING SOLUTIONS

877-322-EDGE(3343) • primedge.com • sales@primedge.com • Fax:224-265-6638

PRIMEedge, Inc. • Cutting Edges • Knife Sharpening Systems • Edge Maintenance Tools • Professional Sharpening Services
Circular Blade & Grinder Plate Sharpeners • Grinder Plates, Knives & Accessories • Sanitizer/Bacteria Reduction Washing Systems